



TECHNICAL MANUAL

DIRECT SUPPORT AND GENERAL SUPPORT MAINTENANCE MANUAL

RADIAC SET AN/PDR-56F (NSN 6665-01-113-9530)

This copy is a reprint which includes current
pages from Change 1.

HEADQUARTERS, DEPARTMENT OF THE ARMY

14 JANUARY 1983



5

SAFETY STEPS TO FOLLOW IF SOMEONE IS THE VICTIM OF ELECTRICAL SHOCK

1

DO NOT TRY TO PULL OR GRAB THE INDIVIDUAL

2

IF POSSIBLE TURN OFF THE ELECTRICAL POWER

3

IF YOU CANNOT TURN OFF THE ELECTRICAL POWER, PULL, PUSH, OR LIFT THE PERSON TO SAFETY USING A WOODEN POLE OR A ROPE OR SOME OTHER INSULATING MATERIAL

4

SEND FOR HELP AS SOON AS POSSIBLE

5

AFTER THE INJURED PERSON IS FREE OF CONTACT WITH THE SOURCE OF ELECTRICAL SHOCK, MOVE THE PERSON A SHORT DISTANCE AWAY AND IMMEDIATELY START ARTIFICIAL RESUSCITATION

CHANGE

HEADQUARTERS
DEPARTMENT OF THE ARMY
WASHINGTON, DC, 15 January 1986

NO. 1

**DIRECT SUPPORT AND GENERAL SUPPORT
MAINTENANCE MANUAL
RADIAC SET AN/PDR-56F
(NSN 6665-01-113-9530)**

TM 11-6665-245-34, 14 January 1983, is changed as follows:

1. Remove and insert pages as indicated below.
2. New or changed material is indicated by a vertical bar in the margin of the page.
3. Added or revised illustrations are indicated by as vertical bar adjacent to the figure caption.

<i>Remove Pages</i>	<i>Insert Pages</i>
i and ii	i and ii
1-1/(1-2 blank)	1-1/(1-2 blank)
2-1 thru 2-4	2-1 thru 2-4
2-7	none
3-1 and 3-2	3-1 and 3-2
3-5 and 3-6	3-5 and 3-6
3-9 thru 3-11	3-9 thru 3-14
A-1/(A-2blank)	A-1/(A-2 blank)
None.....	FO-2

4. File this change sheet in front of the publication.

By Order of the Secretary of the Army:

JOHN A. WICKHAM JR.
General, United States Army
Chief of Staff

Official:

MILDRED E. HEDBERG
Brigadier General, United States Army
The Adjutant General

DISTRIBUTION:

To be distributed in accordance with DA Form 12-36 literature requirements for AN/PDR-56F.

WARNINGS

The check source used in this equipment contains Thorium (a radioactive metal). Thorium is a hazardous material. Injury or disease may result if the Thorium check source is not handled properly. Observe the following precautions:

Do not scratch or abrade the check source in any way to produce small particles. If small particles are produced, use extreme caution to avoid inhalation.

Do not allow particles to enter the body, through open cut or mouth. Wash any area suspected of being contaminated with Thorium with lukewarm water and a non-abrasive soap. Contact qualified medical personnel and the local Radiological Protection Officer (RPO) immediately if you are exposed to check source material. Use extreme care not to touch, scratch, or break or remove the surface of the check source while handling them.

Never place a dislodged check source in your pocket. Do not clean check source with abrasives. Refer to TB 43-01 16, TB 43-0122, and AR 385-11 for instructions on first aid, safe handling, storage and disposal of radioactive material.

High voltages produced in this equipment are exposed when the radiacmeter case is removed and the equipment turned on. Be careful when performing maintenance, take the following precautions:

Never work on the radiacmeter when you don't know the hazards. Become familiar with components that contain or hold high voltage and where high voltage is exposed to contact before turning the equipment on.

Work on the equipment without the equipment on whenever possible.

Protect yourself to reduce injury due to accidental contact with high voltage. Use one hand to make measurement and keep the other hand (or body parts) off ground to eliminate current path through your body.

Become familiar with methods of Artificial Respiration, refer to FM 21-11.

**DIRECT SUPPORT AND GENERAL SUPPORT MAINTENANCE MANUAL
 RADIAC SET AN/PDR-56F
 (NSN 6665-01-113-9530)**

REPORTING ERRORS AND RECOMMENDING IMPROVEMENTS

You can help improve this manual. If you find any mistakes or if you know of a way to improve the procedures, please let us know. Mail your letter, DA Form 2028 (Recommended Changes to Publications and Blank Forms) or DA Form 2028-2 located in back of this manual direct to Commander, US Army Communications-Electronics Command and Fort Monmouth, ATTN: AMSEL-ME-MP, Fort Monmouth, NJ 07703-5007.

In either case, a reply will be furnished direct to you.

TABLE OF CONTENTS

	Paragraph	Page
CHAPTER 1. INTRODUCTION		
Section i. General		
Scope	1-1	1-1
Consolidated Index of Army Publications and Blank Forms	1-2	1-1
Maintenance Forms, Records and Reports	1-3	1-1
Reporting Equipment Improvement Recommendations (EIR).....	1-4	1-1
Section ii. Description and Data		
Description	1-5	1-1
Tabulated Data	1-6	1-1
CHAPTER 2. FUNCTIONING OF EQUIPMENT		
Introduction	2-1	2-1
Block Diagram Analysis	2-2	2-1
Probe Operation	2-3	2-1
Probe Electronics	2-4	2-2.1
Discriminator, Buffer-Inverter Circuit	2-5	2-2.1
Count Rate Circuit	2-6	2-4
Power Supply and Regulator	2-7	2-4
CHAPTER 3. MAINTENANCE		
Section i. General		
Maintenance Procedures	3-1	3-1
Maintenance Data	3-2	3-1
Troubleshooting Chart	3-3	3-5
Equipment Required for Maintenance	3-4	3-5
Operational Test	3-5	3-5
Section ii. Repair of Radiacmeter		
Removal and Replacement of Cover Assembly	3-6	3-6
Removal and Replacement of PCB Assembly	3-7	3-6
Removal and Replacement of Meter Light Assembly and Meter... ..	3-8	3-7
Repair and Replacement of Source Assembly	3-9	3-7

TABLE OF CONTENTS I Continued

		Paragraph	Page
CHAPTER	3. MAINTENANCE - Continued		
Section	III. Repair of Probes		
	Repair of Main Probe and Emitter Follower	3-10	3-7
	Repair of the Aux Probe	3-11	3-10
	Repair of the X-Ray Probe	3-12	3-10
Section	IV. Testing Repaired Equipment		
	Source Test	3-13	3-11
	Light-Leak Test	3-14	3-11
	Calibration of the Radiacmeter	3-15	3-11
	Calibration of the X-Ray Probe	3-16	3-12
APPENDIX	A. REFERENCES		A-1

LIST OF ILLUSTRATIONS

Figure	Title	Page
2-1	Particle Detector Block Diagram	2-2
2-2	X-Ray Probe Block Diagram.	2-2.2
2-3	Main Probe Section	2-3
2-4	Probe Circuit Simplified Schematic Diagram	2-3
2-5	Discriminator Buffer-Inverter Circuits	2-5
2-6	Count Rate Circuit Simplified Schematic Diagram	2-5
2-7	Regulated Power Supply Simplified Schematic Diagram	2-6
3-1	AN/PDR-56F Wiring Diagram	3-2
3-2	PCB Parts Location	3-3
3-3	Voltage Waveforms	3-4
3-4	Radiacmeter, Exploded View.	3-8
3-5	Main Probe, Exploded View.	3-9
3-6	Aux Probe, Exploded View.	3-9
3-7	X-Ray Probe, Exploded View.	3-13
3-8	X-Ray Probe,DT-590A/PDR-56, PCB Parts Locations	3-14
FO-1	AN/PDR-56F Schematic Diagram	Fold out
FO-2	Overall Schematic, X-Ray Probe, DT-590A/PDR-56F	illustration located in back of manual

LIST OF TABLES

Table	Title	Page
3-1	General Support Troubleshooting Chart	3-5
3-2	Operational Test	3-6

CHAPTER 1 INTRODUCTION

Section I.GENERAL

1-1. Scope

This manual covers direct and general support maintenance for Radiac Set (AN/PDR-56F). It includes instructions for direct and general support to troubleshoot and test the equipment and to replace maintenance parts. Detailed functions of the component parts of the radiac set are also included.

1-2. Consolidated Index of Army Publications and Blank Forms

Refer to the latest issue of DA Pam 310-1 to determine whether there are new editions, changes or additional publications pertaining to the equipment.

1-3. Maintenance Forms, Records and Reports

a. *Reports of Maintenance and Unsatisfactory Equipment.* Department of the Army forms and procedures used for equipment maintenance will be those prescribed by 'DA Pam 38-750' as contained in Maintenance Management Update.

b. *Report of Packaging and Handling Deficiencies.* Fill out and forward SF 364 (Report of Discrepancy (ROD)) as prescribed in AR735-11-2/DLAR 4140.55/NAVMATINST 4355.73A/AFR 400-54/MC0 4430.3F.

c. *Discrepancy in Shipment Report.* Fill out and forward Discrepancy in Shipment Report (DISREP) (SF361) as prescribed in AR 55-38/NAVSUPINST 4610.33C/AFR 75-181MC0 P4610.19D/DLAR 4500.15.

1-4. Reporting Equipment Improvement Recommendations (EIR)

If your Radiac Set AN/PDR-56F needs improvement, let us know. Send us an EIR. You, the user, are the only one who can tell us what you don't like about your equipment. Let us know why you don't like the design. Tell us why a procedure is hard to perform. Put it on an SF 368 (Quality Deficiency Report). Mail it to Commander, US Army Communications-Electronics Command and Fort Monmouth, ATTN: AMSEL-ME-MP, Fort Monmouth, NJ 07703-5007. We'll send you a reply.

Section II DESCRIPTION AND DATA

1-5. Description

Refer to TM 11-6665-245-12, Operator's and Organizational Maintenance Manual for Radiac Set AN/PDR-56F, for a general description and illustrations of the equipment.

1-6. Tabulated Data

Refer to TM 11-6665-245-12, Operator's and Organizational Maintenance Manual for Radiac Set AN/PDR-56F, for applicable tabulated data.

CHAPTER 2

FUNCTIONING OF EQUIPMENT

2-1. Introduction

The radiac set is composed of a Radiacmeter IM-160F/PDR-56 (radiacmeter), three probes: DT-224B/PDR-56 (main probe), DT-228A/PDR-56 (auxiliary probe), and DT-590A/PDR-56F (X-ray probe), a set of earphones, an extension handle, a carrying strap, an operator's technical manual, and a case to contain the components. The radiac set is used to detect and measure alpha radiation which penetrates the detecting screen of the main probe (or auxiliary probe) and to detect and measure low energy gamma radiation with the x-ray probe connected to the radiacmeter. The functioning of the equipment will be explained first on a block diagram and then on a detailed analysis of the circuitry.

2-2. Block Diagram Analysis (Fig. 2-1)

The operating portion of the radiac set includes the radiacmeter and the main, auxiliary, and x-ray probes. These items and their circuitry are laid out on the block diagram (fig. 2-1) with the direction of signal flow from left to right. The signal starts in the probe (main, auxiliary, or x-ray) and ends up as both a meter indication and a sound indication in the headset.

a. *Reg Power.* This block supplies power and various voltages to operate the radiacmeter. The power is taken from two dry cells that are installed in the radiacmeter. The relatively low voltage of the dry cells is stepped up through an oscillator-transformer-rectifier arrangement which supplies the different voltages. The regulator portion of this block is used to maintain output voltage constant as the dry cell voltage changes slightly over the battery life.

b. *Probes.* The main and auxiliary probes convert low energy alpha particles into pulses of light for the photomultiplier tube. The x-ray probe senses low energy gamma radiation and produces voltages of sufficient amplitude, which are passed by the discriminator and fed to the count rate meter, which shapes and displays the events per unit of time in the meter circuit.

c. *Photomultiplier and Emitter Follower.* These items are contained in the handle of the main (and auxiliary) probes. The photomultiplier changes the light pulses from these probes into electrical signals. The emitter follower provides impedance matching to the coiled cable which

connects the main and auxiliary probes to the radiacmeter body.

d. *Discriminator.* This block represents two transistors connected to discriminate between low level random noise and actual signals. The discriminator allows signals to pass to the next block, but eliminates the noise signal. The output signal from this block is a constant amplitude pulse which coincides with the light pulse to the photomultiplier (PM) for the beta probes. With the x-ray probe, which has an amplifier-discriminator circuit integral to the probe (self-contained with a scintillator-photomultiplier combination), the resulting signal is coupled to the main discriminator as shown in the block diagram at Figure 2-2.

e. *Buffer-Inverter.* In this block, the signal is inverted and sent to the count rate circuit.

f. *Count Rate.* The count rate block provides a changeable timing circuit so that scales can be changed. Part of the circuit is the scale change switch which selects the proper timing components for changing scale.

g. *Indicating Meter.* This block represents the meter on which the counts per minute (CPM) are read.

h. *Headset Connector.* Provides an output connection for listening to the signal (clicks).

2-3. Probe Operation

Both the main probe and the auxiliary probe operate on the same general principle. They both convert alpha particles to pulses of light and then convert those light pulses to an electrical signal (electrical pulses). The x-ray probe converts gamma radiation incident to its scintillator-photomultiplier from light pulses to an electrical signal.

a. *Main Probe.* Figure 2-3 shows a cut away view of the inside of the main probe. The base and cover form a light tight covering for the photomultiplier tube. Slots cut into the metal base bottom form the area (window) where alpha particles are detected. The window area is also sealed to keep light from entering by a sandwich formed of a piece of clear lucite and a piece of very thin aluminum foil bonded to clear plastic (aluminized mylar). Directly above the aluminized mylar is a layer of phosphor, a chemical substance that gives off light when activated by radiation. Above the lucite are pieces of clear

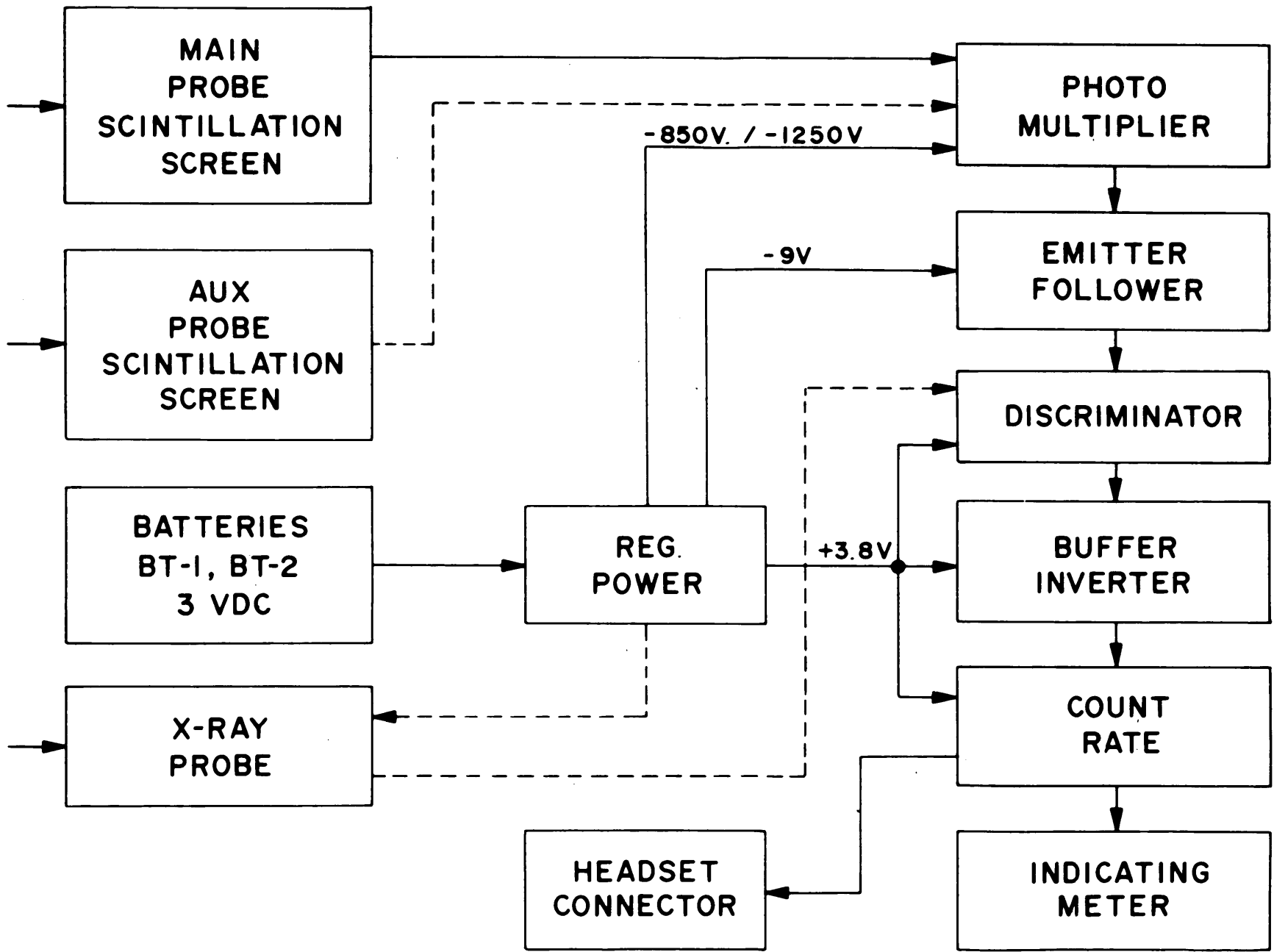

Figure 2-1. Particle Detector Block Diagram

EL501001

plastic called light pipes which direct light generated in the phosphor to the photomultiplier tube. Alpha particles are detected when the base of the probe is placed over or close to materials giving off alpha rays. The alpha particle penetrates the phosphor through the slots in the base and the aluminized mylar. Each alpha particle activates the phosphor it penetrates causing a small speck of light to be generated. The light in turn is directed through the light pipes to the photomultiplier where the light is changed to an electrical signal.

b. *Auxiliary Probe.* The auxiliary probe functions in the same manner as the main probe except that it is smaller and has no light pipes.

c. *X-Ray Probe.*

NOTE

In addition to emitting 5.1 MeV alpha particles, the element Plutonium-239 also emits x-rays in the energy range of 14 to 21 keV. Because these x-rays are more penetrating than the alpha particles, they travel further in matter and air and can be detected at further distances from the ground.

The x-ray probe uses a $\text{CaF}_2(\text{Eu})$ scintillator-photomultiplier combination to detect the 14-21 keV x-rays from Pu-239. The photomultiplier tube fits into a tube socket with a voltage divider network to supply the dynode voltages. A mu-metal shield surrounds the phototube to protect it from gain changes due to stray magnetic fields or from changes in orientation with respect to the earth's magnetic field. The x-ray probe is an assembly which includes the amplifier-discriminator circuits integral to the phototube scintillator housing. The discriminator is a single channel analyzer adjusted to detect Pu-239 x-rays.

2-4. Probe Electronics (Figures 2-4 and FO-2)

a. *Main and Auxiliary Probes.* The probe circuitry contains a photomultiplier tube (Vi) and transistor Q1. Voltages of minus 950 and minus 9 are supplied from the radiacmeter through the coil cord. The signal from the main probe (and) auxiliary probe is also carried to the radiacmeter through the coil cord.

(1) V1, the photomultiplier tube, receives light pulses on its cathode. A light pulse releases electrons from the cathode which are attracted to dynode one (pin 1) because it is more positive than the cathode. When the electrons from the photo cathode strike the first dynode, more elec-

trons are released from it than strike it and they are attracted to dynode two because it is more positive than dynode one. This action continues through nine dynodes providing more and more electrons as it gets closer to the collector (pin 10). The collector absorbs the electrons and they flow to ground through resistor R11 forming a negative going voltage pulse which represents the alpha particle which has been detected.

(2) Transistor Q1, resistors R12 and R13 and capacitors C3 and C4 are used to counteract the effect of the coil cord capacitance on the signal. The output of the transistor Q1 is a low impedance to match the coil cord. Resistor R12 and capacitor C4 form an integrating circuit to shape the pulse waveform. Capacitor C3 and resistor R13 counteract the distributed capacitance of the coil cord to ground.

b. *X-Ray Probe.* (Figure FO-2). The X-Ray Probe circuitry contains a PM tube (V2), a pulse amplifier (Q10, 11, 12) and a simple channel analyzer (U1,2). Voltages of -950 VDC, + 3.38 VDC, and -9 VDC are supplied from the radiacmeter through the coiled cord. The signal from the x-ray probe is also carried to the radiacmeter through the coil cord.

(1) With the lower and upper discriminator (U1) thresholds at typical -2.3 VDC and -6 VDC respectively, the amplifier gain is adjusted such that the low discriminator triggers for energies 14 keV and above and the upper discriminator triggers for energies 22 keV and above. U2 (pins 1, 2, 3, 4, 6) is a one shot which shapes the output pulses. U2 (pins 10, 11, 12, 14) is a flip-flop which is set by the upper discriminator output and thus inhibits the one shot output.

(2) Resistors R64, R65, and R66 are shorted as needed to provide the required voltage for the photomultiplier tube (V2).

2-5. Discriminator, Buffer-Inverter Circuit (Figure 2-5)

The discriminator and buffer-inverter circuit determines the level of pulses which are measured and provides a positive going pulse for use by the count rate circuit (U1).

a. In the static condition, Q2 is conducting and Q3 and Q4 are held cut off. The positive voltage from voltage divider consisting of R17 and R18 biases Q2 on and sets the emitter voltage of Q2 positive. This in turn biases Q3 off which biases Q4 off.

b. Negative going pulses are received from the probe along with noise across resistor R14. Before the negative going pulse can cut off Q2, it must overcome the positive bias set by R18. R18

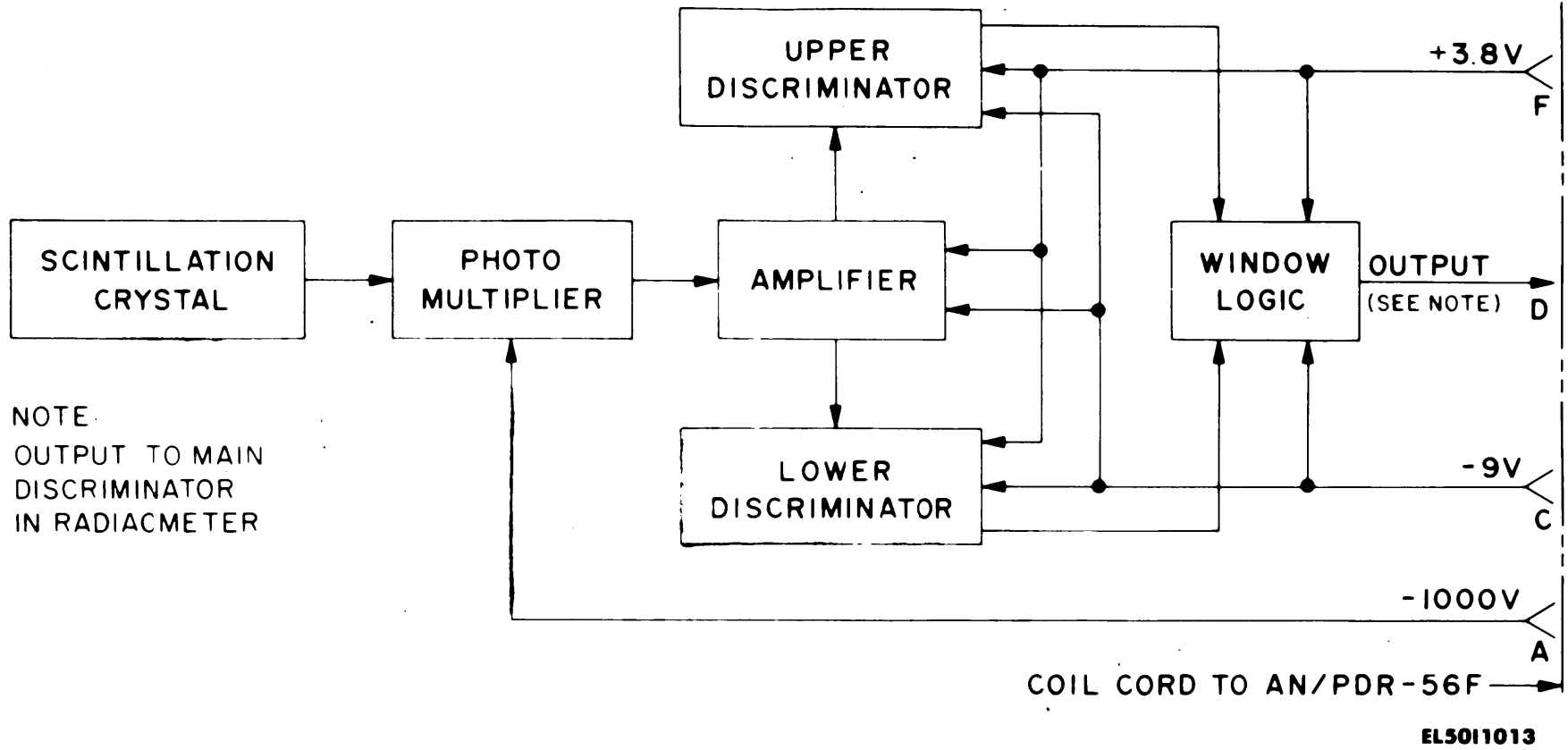

Figure 2-2. X-Ray Probe Block Diagram

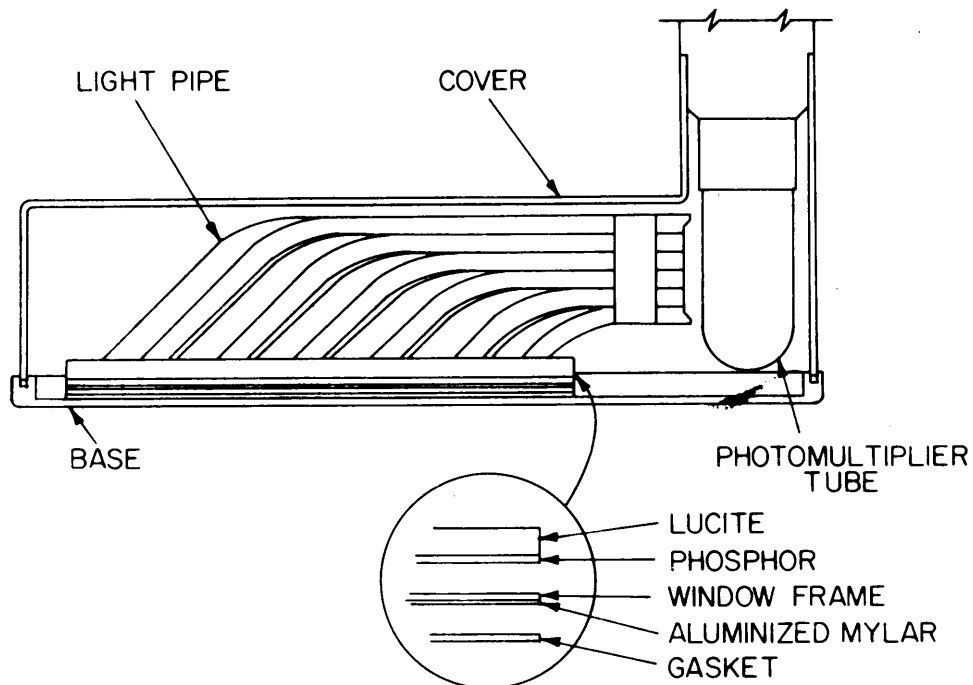
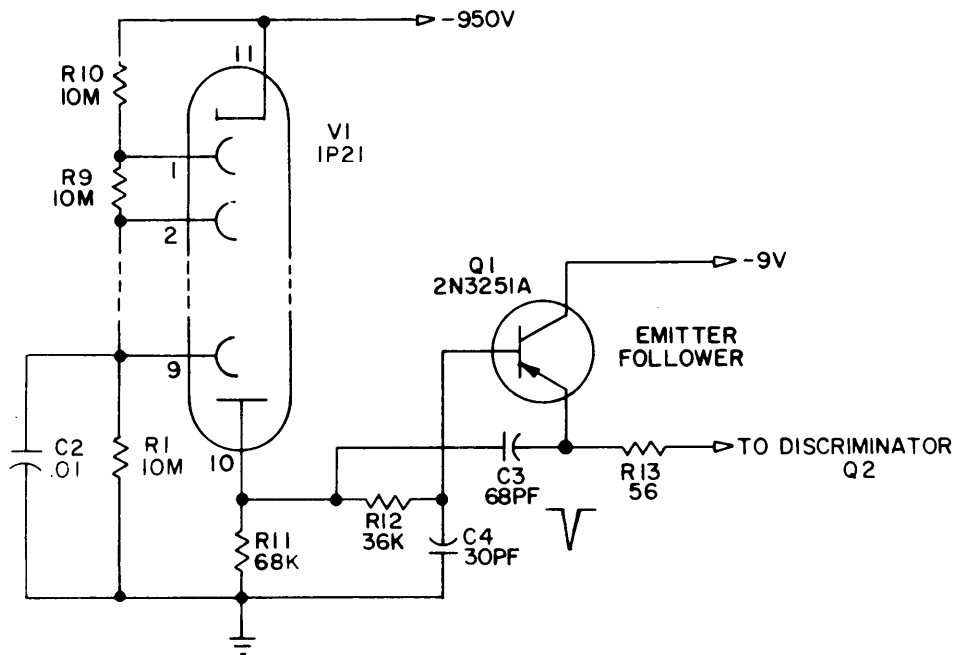

Figure 2-3. Main Probe Section



EL50I003

Figure 2-4. Probe Circuit Simplified Schematic Diagram

is set so that small magnitude signals (noise) are eliminated.

c. Once Q2 is cut off, Q3 and Q4 turn on providing a positive going pulse to be formed across resistor R21.

2-6. Count Rate Circuit (Figure 2-6)

a. The count rate circuit consists of NOR gate U1A, NOR gates U1B through U1D connected as simple inverters, and transistor Q5 which is used in a feedback loop to control U1A. Prior to any signal (positive pulse from the buffer inverter circuit Q4), the inputs (pins 1 and 2) to NOR gate U1A are both low, the output (pin 3) is high and transistor Q5 is conducting.

b. The positive going pulse from the buffer-inverter starts the circuit into operation. When pin 2, U1A, goes high, pin 3, its output goes low. The voltage change is coupled directly to the base of Q5 through timing capacitor C21. Q5 is then cut off and its collector goes high holding the output of U1A low. This condition holds until timing capacitor C21 discharges through resistor R23 enough to allow Q5 to turn on, causing pin 1 of U1A to revert to a low condition. This action results in pin 3, U1A, first going low as the result of the inverter-buffer input pulse and then staying low until the timing capacitor discharges forming a negative going pulse on the input of U1B through U1D.

c. The negative going pulse at pin 3, U1A, is started by the inverter-buffer pulse. Its length is determined by the discharge time of C21 when S1 is in the position shown. When S1 is in other ranges, the value of the timing capacitor changes and so does the length of the output pulse. These different pulse lengths are used for different ranges and cause the meter to read correctly as scales are changed.

d. Outputs from U1B and U1C are tied together and connected to the indicating meter through potentiometer R26, resistor R27, switch S1, and resistor R33. Since the meter cannot respond to the pulse, capacitor C23 is connected

across the meter. The capacitor is charged by the pulse and then discharges through R33 and the meter to provide a steady reading on the meter. Capacitor C24 is switched into the meter circuit on the 1M and 1K positions of the selector switch and combines with C23 to change the time constant required on those ranges.

e. The output of U1D is used to energize the headphones (when used) and provides the "click" noise in the earpiece for each pulse received from the inverter-buffer stage.

2-7. Power Supply and Regulator (Figure 2-7)

The power supply and regulator circuit uses the voltage input from the two radiacmeter batteries. The output voltages which operate the radiacmeter circuits are: minus 950, minus 9, and plus 3.8 volts dc. These voltages are generated from a blocking type oscillator circuit using step up voltage windings to generate an ac voltage which is rectified for the dc voltages.

a. The blocking oscillator circuit uses transistor Q6 as the oscillator. The feedback for the oscillator is provided by winding 4-5 of transformer T1 coupled through the transformer's core. The feedback signal alternately cuts off Q6 and drives it into saturation. The length of time Q6 is cut off is controlled by the charge on capacitor C17 and C18. The charge path for C17 and C18 is through and controlled by transistor Q7. Transistor Q7, in turn, is controlled by the differential amplifier pair of transistors Q8 and Q9 to set the charge (voltage of C18). Controlling the voltage on C18 then controls the time Q6 is cut off, which controls the frequency of the oscillator and the three power supply outputs.

b. Three ac output voltages are taken from transformer T1. There is a separate winding between pin 6 and either pins 7 through 11 for the high voltage supply and a common winding (pins 1, 2, and 3) to provide the low voltage outputs. Both low voltage outputs use voltage doubler type rectifier arrangement to obtain their outputs. The high voltage rectifier arrangement is a voltage tripler.

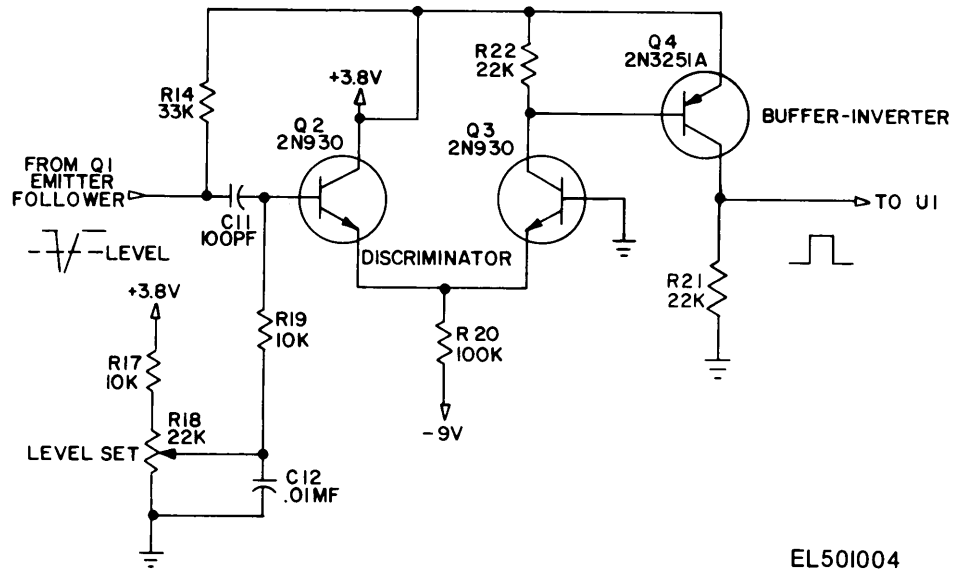

EL501004

Figure 2-5. Discriminator Buffer-Inverter Circuits.

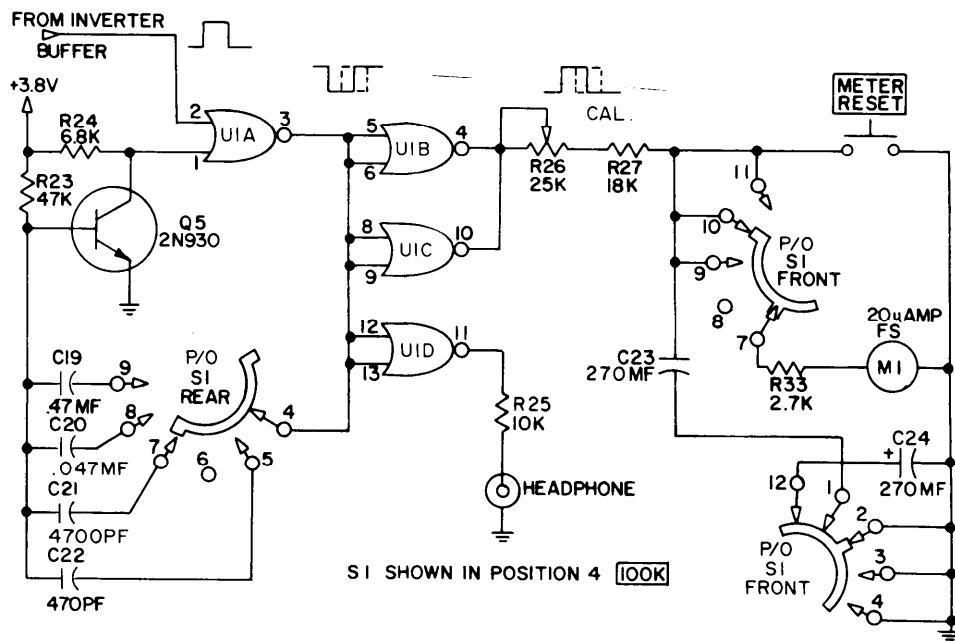

EL501005

Figure 2-6. Count Rate Circuit Simplified Schematic Diagram.

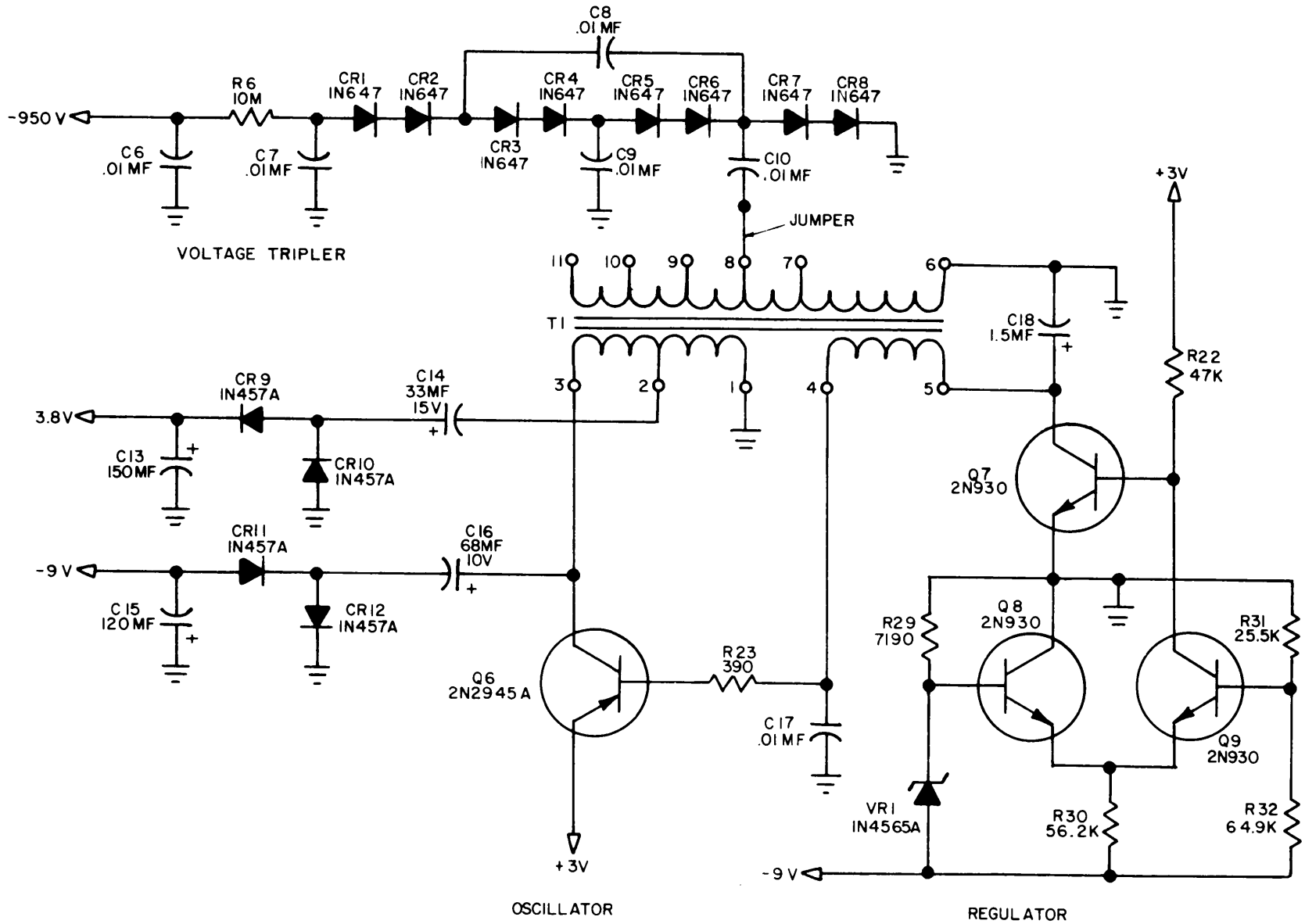

Figure 2-7. Regulated Power Supply Simplified Schematic Diagram.

EL501006

CHAPTER 3 MAINTENANCE

Section I. GENERAL

3-1 Maintenance Procedures

a. *Location of Troubles.* The location of troubles begins with the gathering of symptoms. Then, with knowledge of the equipment functioning, a determination can be made as to what sub-system is defective. From that point, more symptoms are taken, usually with the use of test equipment and further determination can be made until the faulty component is located. This process is called localization and isolation and is the general troubleshooting procedure that should be followed to locate troubles.

b. *Gathering Symptoms.* The skill of gathering symptoms is learned from experience on the equipment. Without this skill, it is best to follow a set procedure based on the following:

(1) Make a quick, visual check of the equipment to try and spot obvious troubles quickly rather than as a result of a lengthy testing or troubleshooting procedure. Use the quick visual check at each stage of the disassembly of the equipment, not just at the start of the procedure.

(2) Do the easy things first. Check for: blown or missing fuses; bad power cables and connectors; make the checks which are simple and fast to do.

(3) Perform an operating procedure to quickly check all controls, switches, and indicators. In the case of the radiacmeter, the operational test (para. 3-5) should provide quick symptoms of trouble. If it doesn't, perform all the tests in paragraphs 3-12 through 3-14. If no symptoms appear, the equipment does not contain any faults.

c. *Repair of Equipment.* Repair of the equipment in most cases will 'probably be the exchanging of defective parts, printed wiring boards, or assemblies with new ones. Procedures for replacing the radiacmeter assemblies are contained in paragraphs 3-6 through 3-12. The extent of further repair depends upon the equipment's maintenance concept as presented in the Maintenance Allocation Chart (TM 11-6665-245-12) and the repair parts available (TM 11-6665-245-23P). Certain parts can be replaced without affecting the equipment's calibration, while adjustments must be made when other parts are replaced. After a repair is made, and prior to testing, check in paragraphs 3-15 and 3-16 to find out if adjustments are necessary.

d. *Testing Repaired Equipment.* Once the equipment fault has been located and corrected, the equipment should be put through a series of tests to determine if it is ready to be returned to service. The complete test for the radiacmeter is contained in paragraphs 3-13 through 3-16. Perform all procedures contained in those paragraphs after repair of the equipment.

e. *Precautions.* Certain precautions should be observed while working on the radiacmeter. The precautions concern possible injury from electrical shock and damage to the photomultiplier tube when it is exposed to light.

(1) High voltage of approximately 950 volts is used to energize the photomultiplier tube contained in the probe handle. The high voltage is generated on the radiacmeter printed circuit board and transmitted through the coil cord to the probe handle. Be sure to locate the high voltage points on the printed circuit board (PCB) prior to energizing the equipment when troubleshooting.

(2) The photomultiplier (PM) tube must be protected from bright light when the equipment is off. When the equipment is on, no unintended light should be allowed to touch it. Under some conditions, light will either damage the tube or reduce its operating life.

f. *Measuring the High Voltage.* The power supply which produces the -950 used for the photomultiplier tube circuit has a very high internal impedance. This presents a problem when trying to make voltage measurements using conventional meters. This is because the amount of current drawn by a conventional meter will reduce the voltage being measured. In order to get an accurate reading, a meter that draws no current (electrostatic voltmeter) or very little current (high input impedance vacuum tube voltmeter) should be used. When those types of meters are not available, use a conventional meter, but realize that the voltage value read has been reduced, possibly up to several hundred volts, from the actual value.

3-2. Maintenance Data

Maintenance data in this manual for the radiacmeter includes: schematic and wiring drawings, (Figures 3-1, FO-1, and FO-2); parts location illustrations (Figures, 3-2 and 3-4 through 3-8); and voltage waveform data (Figures 3-3 and 3-8).

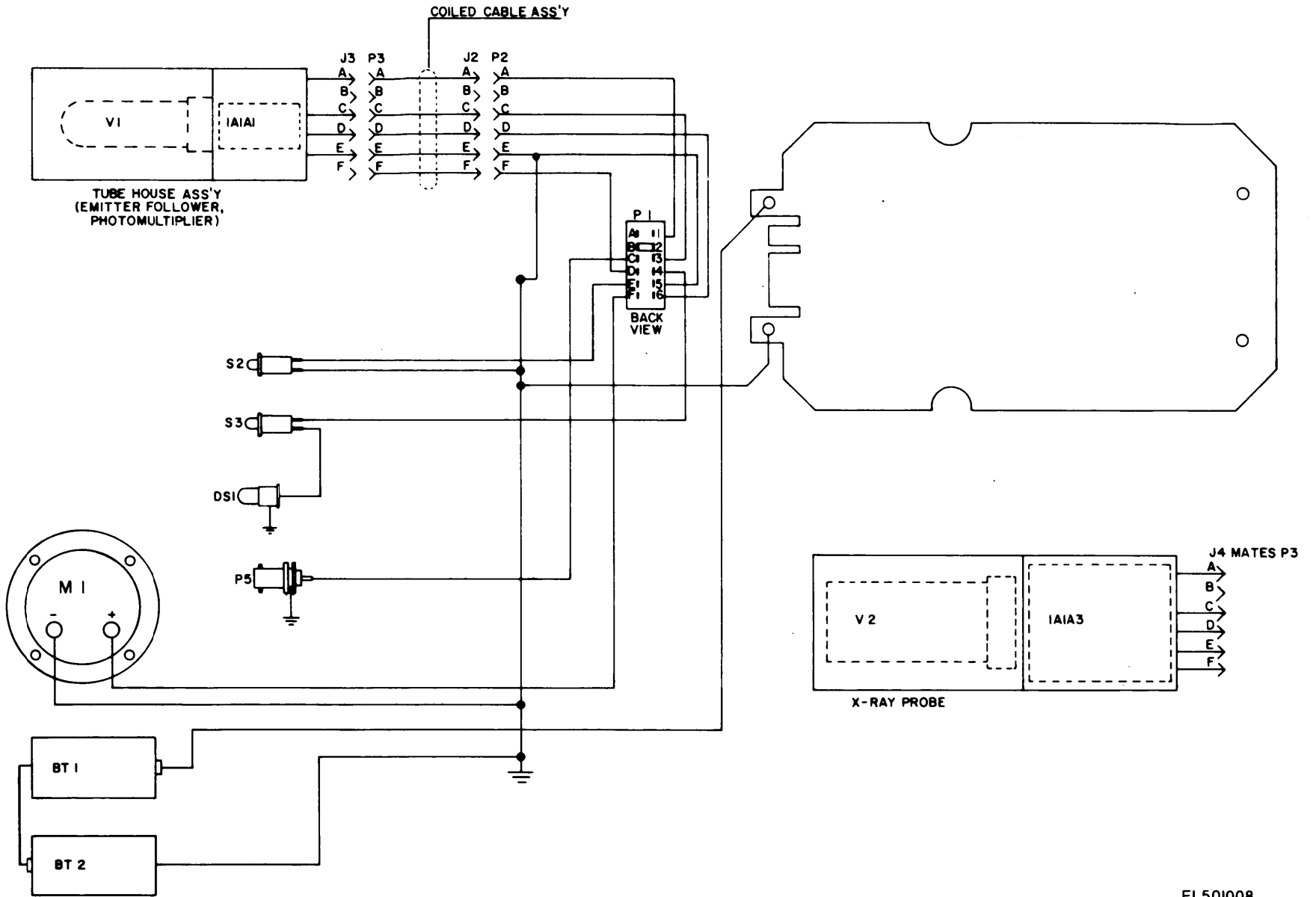
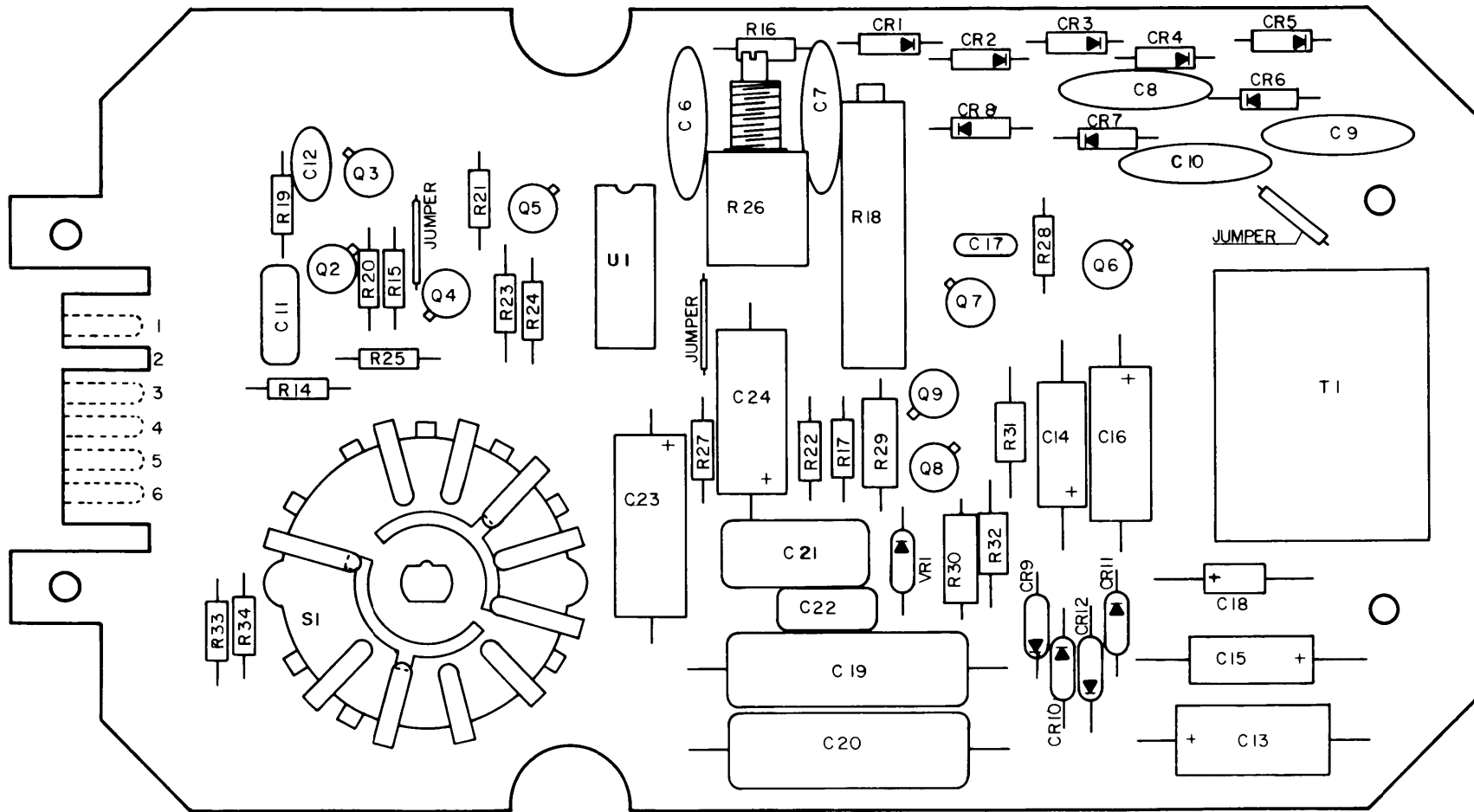
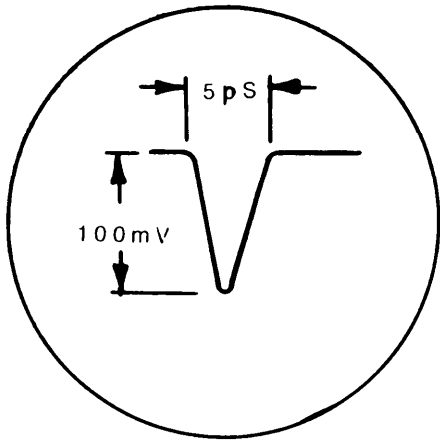

Figure 3-1. AN/PDR-56F Wiring Diagram

EL501008



EL5010 10



Q2 BASE

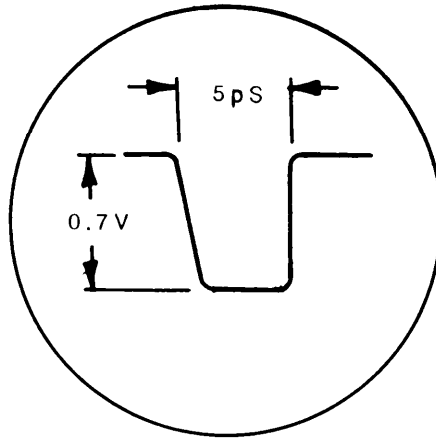

Q3 COLLECTOR

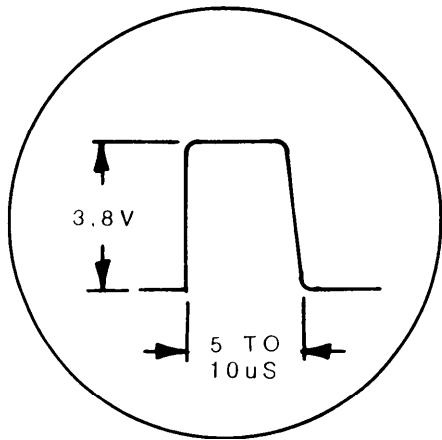

Q4 COLLECTOR

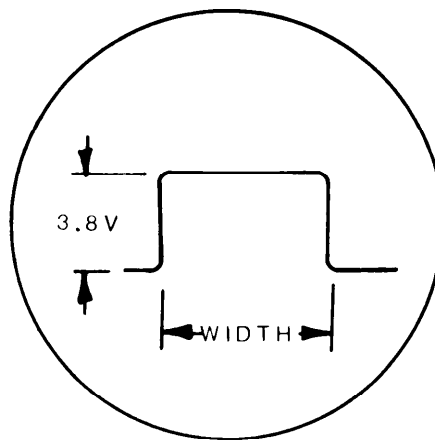

Q5 COLLECTOR

RANGE	WIDTH
1M	20uS
100K	200uS
10K	2uS
1K	20uS

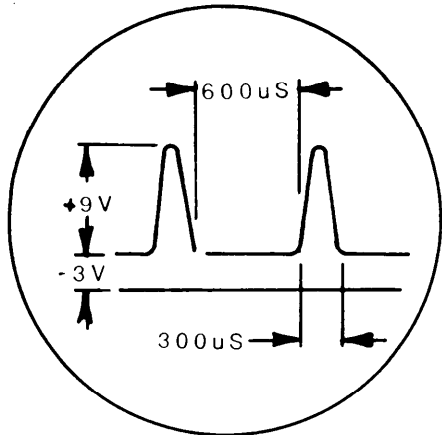

Q6 BASE

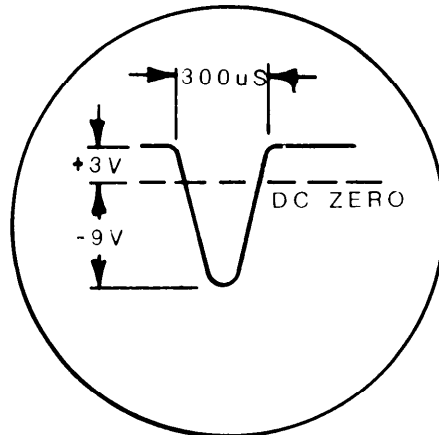

Q6 COLLECTOR

NOTE: CHECK SOURCE IN PLACE

EL501011

Figure .3-3. Voltage Waveforms.

3-3. Troubleshooting Chart

Besides the maintenance data (para. 3-2) provided for fault location, a troubleshooting chart, Table 3-1, is also included. The troubleshooting chart provided is made up from typical or expected troubles. The chart is organized to present first the symptom (malfunction) of the trouble; the test or inspection which should be logically made as a result of the symptom (malfunction); and the corrective action required to correct the malfunction (symptom). The way to use this chart is not to go through it step by step, but to look for the symptom which closely matches the particular one you are trying to correct. Once the symptom has been selected, make the tests or inspections indicated. The corrective action should be completed when

the test or inspection locates a failure. Retest to determine if the symptom (malfunction) has been corrected.

3-4. Equipment Required for Maintenance

The tools and general test equipment required for maintenance are listed in the Maintenance Allocation Chart (MAC) contained in TM 11-6665-245-12. There are no special tools required for maintenance.

3-5. Operational Test

The operational test (table 3-2) is designed as a quick check of the equipment for the repair person to use in developing symptom. If the equipment passes the test, you can be pretty well

Table 3-1. General Support Troubleshooting Chart

Malfunction	Test or inspection	Corrective action
1. Meter scale does not change when selector switch is moved through its positions.	a. Inspect selector switch know to be sure its firmly held on to the selector switch shaft. b. Remove radiacmeter panel and examine linkage from meter to selector switch while moving the selector switch through its positions.	Tighten loose setscrews on linkage or knob.
2. Meter needle reads upscale when no radioactive source is near probe window.	a. Probe may possibly be contaminated with radioactive materials. Use a known good AN/PDR-56F and check for contamination. b. Inspect for probe window light barrier puncture by passing light over the probe window area. Use just enough light to produce meter indication.	a. Decontaminate probe. b. Change light barrier.
3. No meter readings on any range when check source is placed across probe window area.	a. Connect earphones and listen for clicks on all ranges. If clicks are not heard, suspect a faulty coil cord, and try to work the cord into different positions with both hands while watching for a normal meter reading. b. If clicks are heard on the earphones without a meter indication, suspect either a faulty meter switch, faulty meter, or wiring problems.	a. Replace faulty cord. b. Replace faulty meter.
4. No meter readings on one range when the check source is placed across probe window area. Other ranges indicate normally.	Examine switch S1 front and back wafers. Look for bent or loose contacts. Check for signal path through switch in the bad range using continuity function of multimeter.	Replace or repair faulty meter wafer.
5. No audio output at headphones on any range when check source is applied to probe window. Meter readings are normal.	Check continuity from center electrode of phones jack to pin 11 of U1. If continuous, suspect faulty U1. If open, suspect faulty connector P1 on circuit board.	Replace U1 or P1.
6. No meter readings or audio is heard on any ranges.	Check low voltage supply readings. If either voltage is missing or half value, suspect open diodes CR9 thru CR12. Check each diode for proper front to back resistance ratio.	Replace faulty diode.

Table 3-2. Operational Test

Procedures	Normal Results
<p style="text-align: center;">NOTE</p> <p>Procedures 1 through 7 must be repeated for each probe.</p> <ol style="list-style-type: none"> 1. Set selector switch in the following positions in sequence. <ol style="list-style-type: none"> a. BATT b. 1M c. 100K d. 10K e. 1K 2. Disconnect handles and place probe window on check source. 3. Set selector switch to 10K and press METER RESET pushbutton immediately on changing scales. 4. Connect headphones to panel connector and listen while moving source back and forth on probe window to maximize needle indication. 5. Remove headphones and then set selector switch to 100K position. 6. Switch to 1M position. 7. Allow light to hit probe window area while watching meter needle. If needle goes upscale, immediately cover probe window area, removing light. If needle does not go upscale, increase light to window area. 8. Press meter light switch on handle while watching for light at top of meter scale. 	<ol style="list-style-type: none"> a. Meter scale (change window) shows OFF-BATT. Needle indicates in the BATT area. b. Meter scale shows red, 1 M scale. Needle is at zero after 1 or 2 seconds. c. Meter scale shows orange, 100K scale. Needle is at zero. d. Meter scale shows magenta, 10K scale. Needle is at zero. e. Meter scale shows yellow, 1 K scale. Needle is at zero. <p>Meter needle pegs upscale.</p> <p>Meter needle moves to zero when METER RESET switch is held down; moves upscale when METER RESET switch is released.</p> <p>Clicking in headset can be heard to increase and decrease with needle swing.</p> <p>Needle moves downscale to very low reading.</p> <p>Needle moves to zero or very low scale reading,</p> <p style="text-align: center;">CAUTION</p> <p>Be careful when allowing light to fall on bottom of main probe. Do not allow meter needle to peg or damage to the photomultiplier tube may result.</p> <p>Needle remains at zero.</p> <p>Meter lights when switch is held down,</p>

assured that the equipment is working properly and can go for calibration. If an item or function fails the test, this will then develop symptom or a combination of symptoms to use in the troubleshooting table 3-3. To use the table, follow the directions in the procedures column to obtain the results in the normal results column. Start

first by installing two good batteries. Be careful to keep probe window area shaded from light after the equipment is turned on. If main or x-ray probe light barrier is damaged, photomultiplier tube may be destroyed from excess current. The auxiliary probe is tested using a light source to find light leaks rather than an electrical test as done with the main probe.

Section II. REPAIR OF RADIACMETER

3-6. Removal and Replacement of Cover Assembly (Figure 3-4)

The cover assembly of the radiacmeter consists of the meter panel and all mounted hardware including the printed circuit board and electronics inside the case. In order to remove and replace the cover assembly, simply loosen the six screws which hold the panel and case together.

3-7. Removal and Replacement of PCB Assembly (Figure 3-4)

- a. Loosen six screws on the radiacmeter until the panel and case can be separated. The selector switch must be in the OFF position.
- b. Remove connector J2 that connects the wiring harness to the PCB by grasping the connector with the thumb and forefinger and pulling the connector.

away from the board. The pull must be straight.

c. Remove the four screws that attach the PCB to the main panel of the radiacmeter.

d. Lift the PCB up from the selector switch, and away from the main panel. Use extreme caution not to break the switch.

e. Install a new PCB using the reverse procedure of (a) through (d) above. Use extreme caution when installing the new PCB on the shaft of the selector switch. Alignment of the wafer switch to the shaft must be exercised with great care. Replace screws and connector.

3-8. Removal and Replacement of Meter Light Assembly and Meter (fig. 3-4)

a. *Meter Light Assembly.* Replacement of the meter illumination lamp bulb is accomplished as follows:

- (1) Open the radiacmeter.
- (2) Remove the A2 printed circuit board.
- (3) Remove two screws and two large spacers holding the meter assembly in place.
- (4) Note the position of the meter coupling on the rear of the meter. Loosen the meter coupling screw and lift the coupling off the rear of the meter. This must be done with care and without undue force so as not to damage the coupling or the meter.
- (5) Loosen the screw at the top of the meter assembly that is used to mount the meter illumination lamp, DS1, to the assembly. Be careful not to break the meter wire during this operation.
- (6) Swing the small lamp bracket so that the lamp is fully exposed.
- (7) Push the lamp out of its mounting from the front of the meter assembly panel.
- (8) Install a new lamp by reversing the procedure.

b. *Meter Replacement.* Replacement of the indicating meter is accomplished as follows:

(1) Remove A2 PCB as outline in paragraph 3-7.

(2) Using 3/32 inch allen wrench, loosen the screw on the flag clamp and the switch clamp. Slide assembly and remove from meter.

(3) Unsolder meter wires. Observe wire color and polarity.

(4) Remove the two front hex spacer posts.

(5) Remove the two rear screws holding meter plate. Retain two rear spacers for reassembly.

(6) Unscrew four screws holding meter to plate. Retain all hardware for reassembly.

(7) Reassemble new meter in reverse order.

(8) Turn S1 to OFF position, reset meter flag to OFF-BATT. Reset clamps and tighten setscrews.

(9) Check scale registration on all ranges and trim meter flag as necessary using long nose pliers.

3-9. Repair and Replacement of Source Assembly (fig. 3-4)

WARNING

Radioactive material used in the source assembly can be dangerous if it is broken into small pieces that can be inhaled or ingested. Serious injury can result if these small particles get into the body. Be careful when removing and replacing the source material. All broken pieces should be accounted for and placed in a sealable container.

a. Remove the source frame which protects the source. Use a putty knife to pry up one edge and then pull the frame from the bottom of the radiacmeter case.

b. Remove the source material by using the same procedure as used to remove the source frame.

c. Clean the bottom of the case using a suitable solvent.

d. Install a new source and source frame. Use pliobond and cement to the bottom of the case.

Section III. REPAIR OF PROBES

3-10. Repair of Main Probe and Emitter Follower

a. *Light Pipe and Screen.* The replacement of the light pipe or screen is accomplished as follows:

(1) Remove the two screws attaching the emitter follower to the light pipe assembly.

(2) Firmly grip the emitter follower housing in one hand and the light pipe assembly in the other and pull away from each other. It is preferred that the dismantling of these two units be done in an extremely dark area so that the photo multiplier tube is not exposed to light.

(3) Detach the six screws from the bottom housing plate of the light pipe assembly. This will separate the bottom area of the light pipe from the housing.

(4) Remove the two screws from the light pipe.

(5) Lift the light pipe and screen up and away from the housing plate. Care should be taken not to damage the scintillation screen when removing it from the housing plate.

(6) Align the rubber gasket to the bottom housing plate.

(7) Install new screen assembly or light pipe to the housing plate by using the reverse procedure.

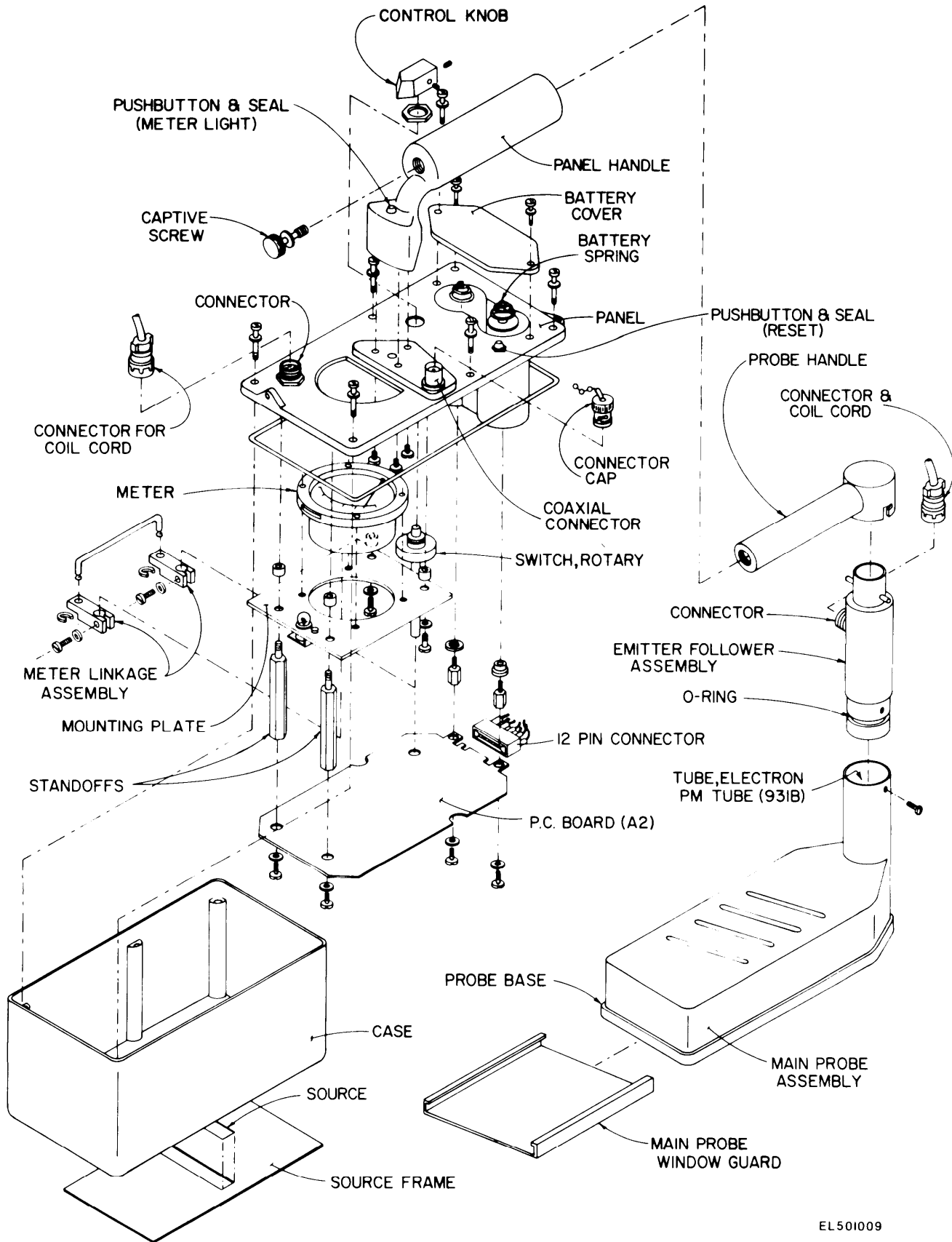

EL501009

Figure 3-4. Radiacmeter, Exploded View

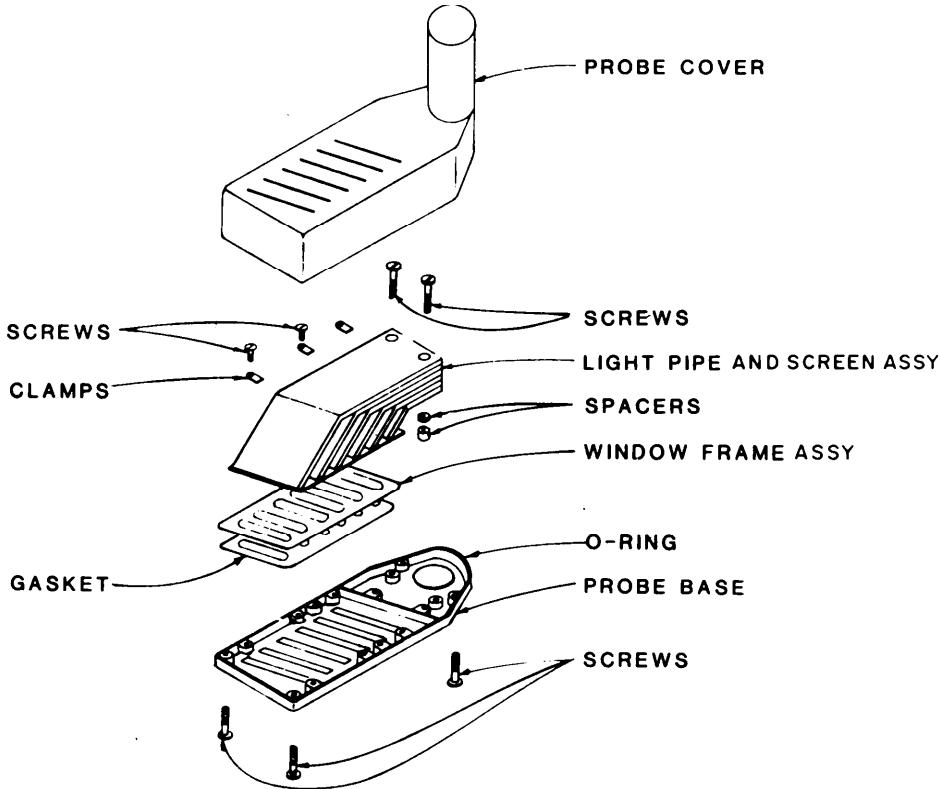

EL501013

Figure 3-5. Main Probe, Exploded View.

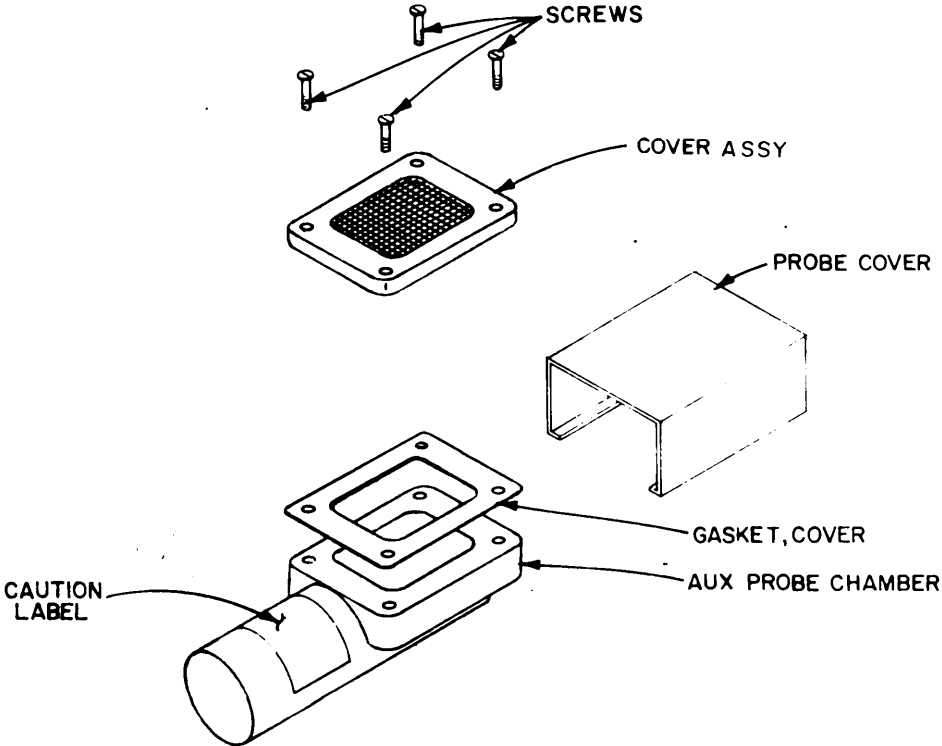

Figure 3-6. Aux Probe, Exploded View

b. Emitter Follower and PM Tube Replacement. Replacement of the emitter follower is accomplished as follows:

(1) Disconnect the coil cord from the emitter follower.

(2) Remove the emitter follower handle by turning the handle until the slot is free from the emitter follower pin. Lift the handle off the emitter follower.

(3) Remove the two screws that connect the emitter follower to the light pipe and screen assembly.

(4) Firmly grip the emitter follower in one hand and with the other hand, pull the main probe assembly away.

(5) Remove the photomultiplier tube slowly and carefully from its socket. Caution must be taken when handling this tube to prevent the bending or breaking of the tube pins or keyway.

NOTE

When handling the photomultiplier tube, do not touch the tube envelope. Handling will create unstable reading when the tube is remounted for use. To correctly handle this tube, grasp it only by its phenolic base.

(6) Discard the old emitter follower since it is unrepairable.

(7) With a new emitter follower, replace the photomultiplier tube, making certain that the keyway of the tube socket is properly aligned.

(8) Remount the emitter follower by using the reverse procedure.

3-11. Repair of the Aux Probe (Figure 3-6)

The aux probe is repaired by replacing a defective cover assembly. The cover assembly is held onto the probe with four screws (Figure 3-6). There are no other repairs. If the aux probe cannot be repaired with the cover assembly replacement, the complete aux probe will have to be replaced.

3-12. Repair of X-Ray Probe (Figure 3-7)

a. To perform maintenance or repair of the x-ray probe, proceed as follows initially:

CAUTION

Handle scintillation crystal assembly carefully so as to prevent damage to mylar window.

(1) Remove cap ring assembly from probe housing and then remove jamb ring and scintillation crystal assembly.

NOTE

When replacing scintillation crystal assembly, you must reseal it to end of PM tube with optical grease to allow proper optical coupling.

(2) Unscrew the end cap (near the handle) from the probe.

(3) Remove the connector nut from the connector and depress the connector into the probe housing.

(4) Remove retaining ring from probe with a retaining ring extractor.

CAUTION

Handle PM tube gently when removing to prevent damage. Do not touch the sides of the PM tube. Touching the sides can create unstable readings when the tube is remounted for use.

(5) Slide assemblies out of the housing by pushing gently on the PM tube from the cap ring end of the housing.

b. Removal and Replacement of PM Tube (Figure 3-7).

CAUTION

Handle PM tube gently when removing to prevent damage. Do not touch the sides of the PM tube. Touching the sides can create unstable readings when the tube is remounted for use. Do not twist PM tube when removing from socket to prevent damage to pins, key or keyway.

(1) Pull the PM tube straight out of its socket, slowly and carefully.

(2) Replace the PM tube, making certain the keyway of the tube socket is aligned with the key of the tube.

c. Removal and Replacement of the Printed Circuit Board (Figure 3-7).

(1) Remove PM tube (para. 3-12. b).

(2) Remove set screws from tube socket clamp.

(3) Using a heat sink, unsolder leads from PCB to tube socket and to connector, marking the location of each lead.

(4) Slide PCB out of the tube socket clamp.

(5) Slide replacement PCB into tube socket clamp and reverse process of c.(1) and c.(2) above.

d. Replacement of Tube Socket Assembly.

(1) Remove PM tube from tube socket (para. 3-12. b).

(2) Using a heat sink, unsolder tube socket assembly leads from PCB.

(3) Replace or repair tube socket, then solder leads back onto PCB.

e. Replacement of Non-Electronic Parts. Replace all remaining parts in kind since they are non-repairable.

Section IV. TESTING REPAIRED EQUIPMENT

3-13. Source Test

a. Remove the main probe "window" protective cover.

b. Set the radiacmeter selector switch to 10K.

c. Uncouple the main probe from the radiacmeter and position it against the check source on the radiacmeter case bottom.

d. Meter should read 6000 & 1200 cpm if the source is to be considered serviceable.

3-14. Light-Leak Test

a. *Main Probe.*

(1) Remove the main probe "window" protective cover.

(2) Set radiacmeter main probe down on a flat surface so that the "window" is covered.

(3) Set the selector switch in the 100K position.

(4) Pick up the main probe and slowly expose it to light while watching the meter. If the meter reading begins to rise when the probe face is exposed to light, immediately remove the probe from the light.

(5) There should not be any meter indication when the probe is exposed to light.

b. *Aux Probe.* Test the aux probe light barrier for light leaks by inspection rather than the electrical method used for the main probe (a. above). Use a suitable light source (flashlight or hand lamp) in a darkened room and direct the light on one side of the probe barrier while inspecting for light leaks on the other. As an alternate method, remove the four screws (Figure 3-6) that hold the cover assembly to the aux probe chamber and inspect the cover assembly for light leaks with a strong light.

c. *X-Ray Probe.*

(1) Connect the x-ray probe to the radiacmeter.

(2) Cover the window of the x-ray probe to prevent entry of light.

(3) Set the selector switch on the radiacmeter to the 1K position.

(4) Pick up the x-ray probe and slowly expose it to a suitable light source (flashlight or hand lamp) while watching the meter.

(5) The meter indication should not rise above 250 cpm. If the meter reading exceeds 250 cpm, immediately remove the probe from the light source.

3-15. Calibration of the Radiacmeter

The radiacmeter is calibrated with the main probe attached (the aux probe is not calibrated) using Radiac Calibrator AN/U DM-7C. Prepare the radiacmeter by installing batteries (selector switch: OFF) and removing the cover. Locate the two adjustable potentiometers R18 and R26 and then proceed below:

a. Check the mechanical zero of the meter and adjust if necessary.

b. Turn R18 (level control fully counterclockwise).

WARNING

High voltages are exposed when the radiacmeter case is removed and the equipment is turned on. Locate the high voltage points on the circuit board BEFORE truning the radiacmeteron. Be careful to avoid contact with the exposed high voltage while making adjustments. Injury from electrical shock may result from touching high voltage.

c. Set selector switch to 10K position. Meter should read upscale a s-small amount. Adjust R18 clockwise to reduce the meter reading to zero.

d. Refer to TM 11-6665-247-10 (AN/U DM-7C) for instructions on setting up the AN/U DM-7C for calibrating the AN/PDR-56F.

NOTE

Always use the instruction in TM 11-6665-247-10 for setting up or packing away the calibrator.

e. Set up the calibrator using attenuator #1 and source A. Remember to remove the main probe window guard from the main probe before setting it in the AN/U DM-7C probe positioner.

f. After the calibrator is set up and the main probe is in position, set the radiacmeter selector switch to 100K position.

g. Set R26 (cal. control) so that the meter reading for the 100K scale is the same value as listed on the calibration report for the AN/UDM-7C.

h. Set up the calibrator using source A only. Then set the radiacmeter selector switch to the 1M position and place the main probe in position on the calibrator.

i. The meter reading should be within the limits specified on the calibration report.

j. Set up the calibrator using source C only. Set the radiacmeter selector switch to the 10K position and place the main probe in position on the calibrator.

k. The meter reading should be within the limits specified on the calibration report.

l. Set up the calibrator using attenuator #1 and source C. Then set the radiacmeter selector switch to the 1K position and place the main probe in position on the calibrator.

m. The meter reading should be within the limits specified on the calibration report.

n. Remove the main probe from the calibrator. The meter reading should go to zero.

o. Set the selector switch to OFF, reassemble the radiacmeter and put the calibrator away.

p. Connect the headset to the radiacmeter and set the selector switch to the 1 K position.

q. Listen in the headset for clicks caused by background radiation. Count the clicks for one minute. The count should not exceed 15 for 1 minute (15 cpm).

3-16. Calibration of the X-Ray Probe

The x-ray probe is also calibrated using the AN/UDM-7 Pu-239 alpha calibration sources. Before calibrating the x-ray probe, the IM-160F/PDR-56 radiacmeter with the main alpha

probe attached must be calibrated. The x-ray probe is then attached to the radiacmeter as outlined in para. 2-2. b of TM 11-6665-245-12. Calibration of the x-ray probe is then accomplished without readjusting the radiacmeter calibration controls or the high voltage setting of the radiacmeter. The calibration of the x-ray probe involves the adjustment of the probe amplifier gain to set the 14-21 keV x-ray photo peak within the discriminator window of the single channel analyzer (SCA). The lower and upper threshold of the SCA are fixed at -2.3 volts and -6.0 volts respectively and should not need adjustment. Once the amplifier gain is properly set, the x-ray probe sensitivity factor (cpm/mg/cm² of Pu-239) is determined using the UDM-7B source A.

Prior to a source calibration, ensure that the probe is functioning. Proceed as follows:

(1) Unscrew the end cap from the probe, exposing the two calibration potentiometers and related test points.

(2) Position the phosphor end of probe approximately one inch from a UDM-7 "A" source.

(3) Turn selector switch to 100K scale.

(4) Connect Digital Voltmeter or Multimeter to Test Point 2 (Figure 3-8) and check for -2.3 Vdc \pm 0.1 Vdc.

(5) Connect Digital Voltmeter or Multimeter to Test Point 3 (Figure 3-8) and adjust R54 for -6.0 Vdc \pm 0.1 Vdc.

(6) Connect oscilloscope probe to Test Point 1 of Figure 3-8 and adjust R49 so that the center band of negative pulses is between -3.5 and -4 V (refer to wave shape on Figure 3-8).

(7) The meter reading of a properly calibrated probe should be in the range of 32 to 40 K cpm.

(8) Secure the calibration pots with glyptol (or equivalent).

(9) Reinstall end cap on the probe.

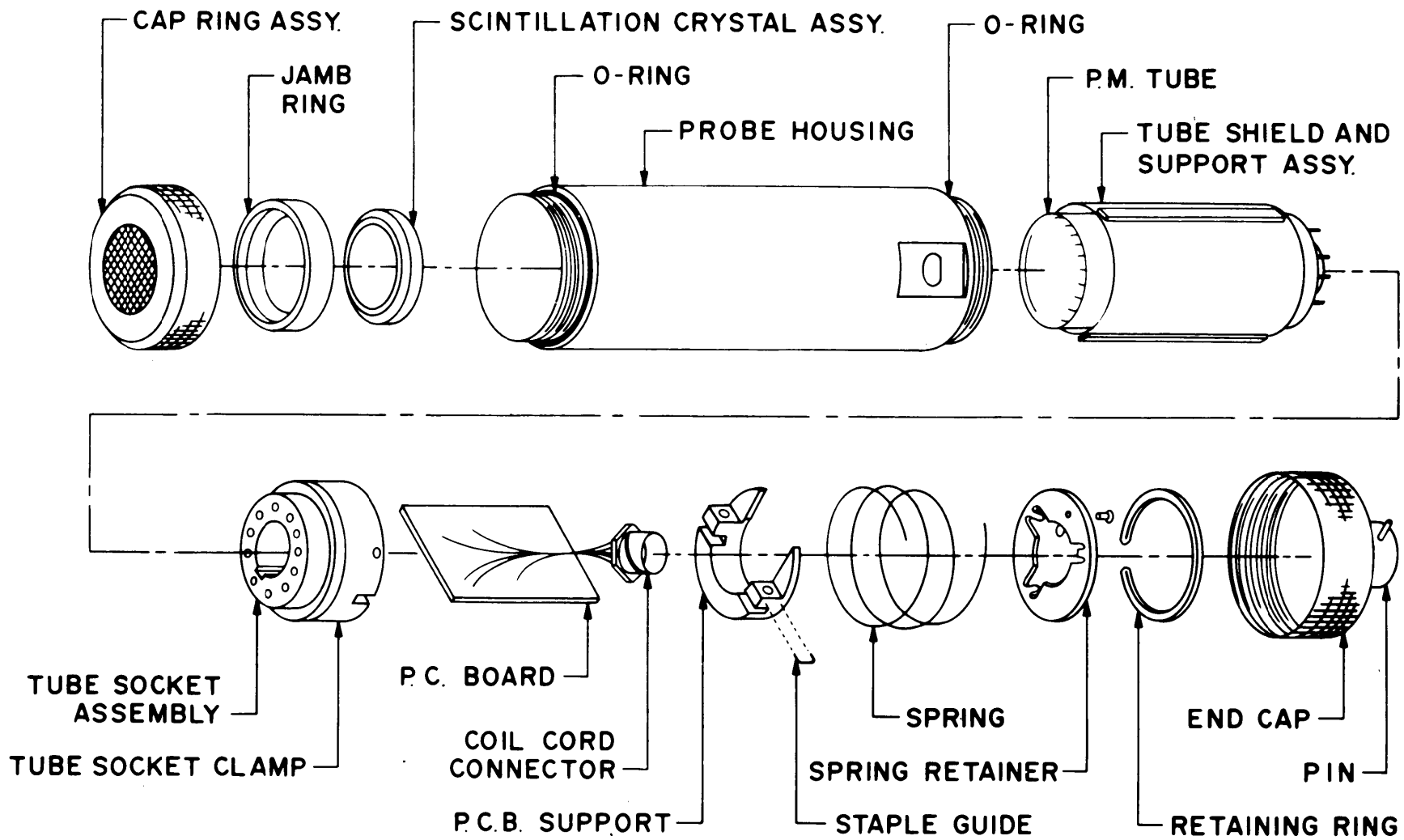

EL501014

Change 1 3-13

Figure 3-7. X-Ray Probe, Exploded View

TM 11-6665-245-34

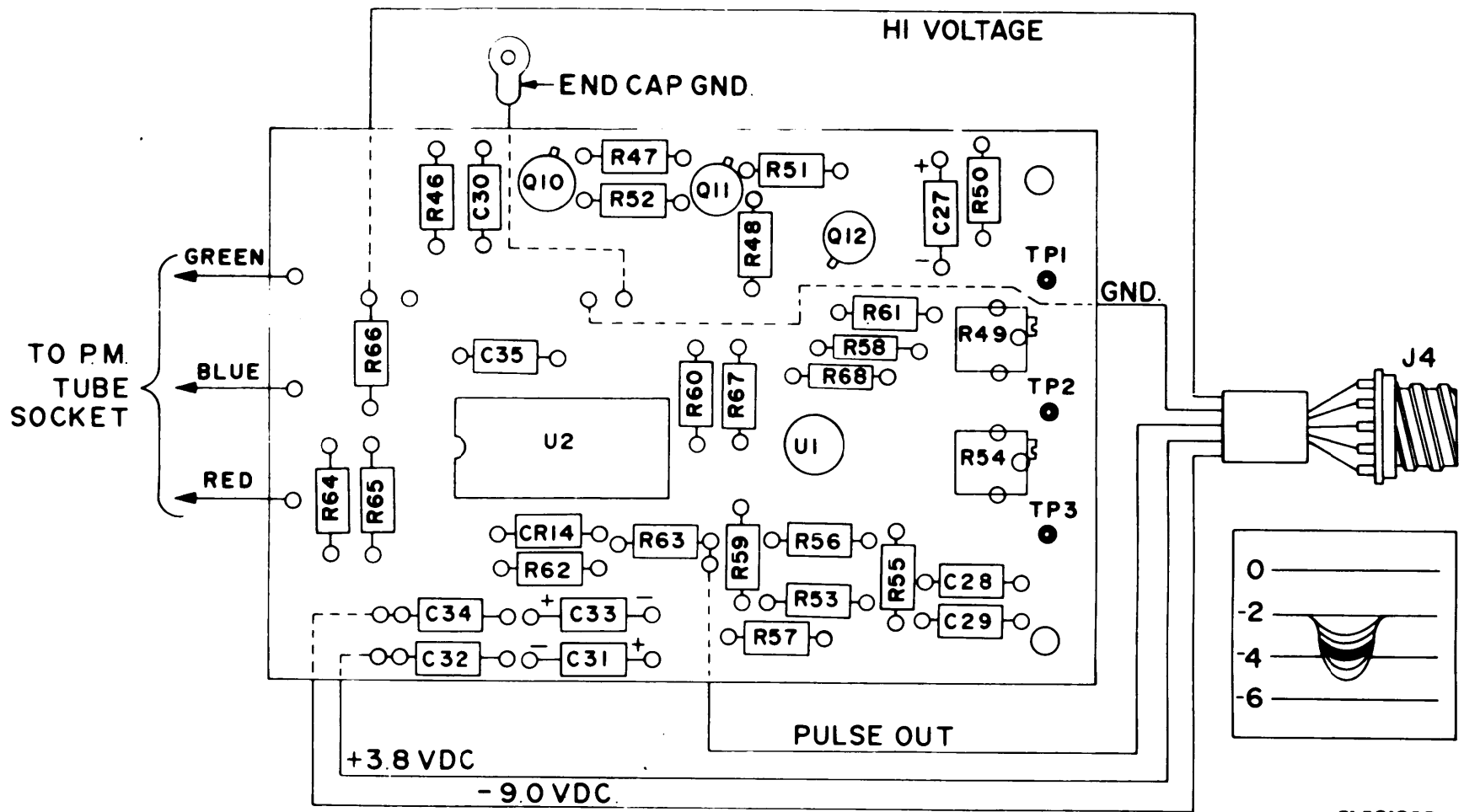
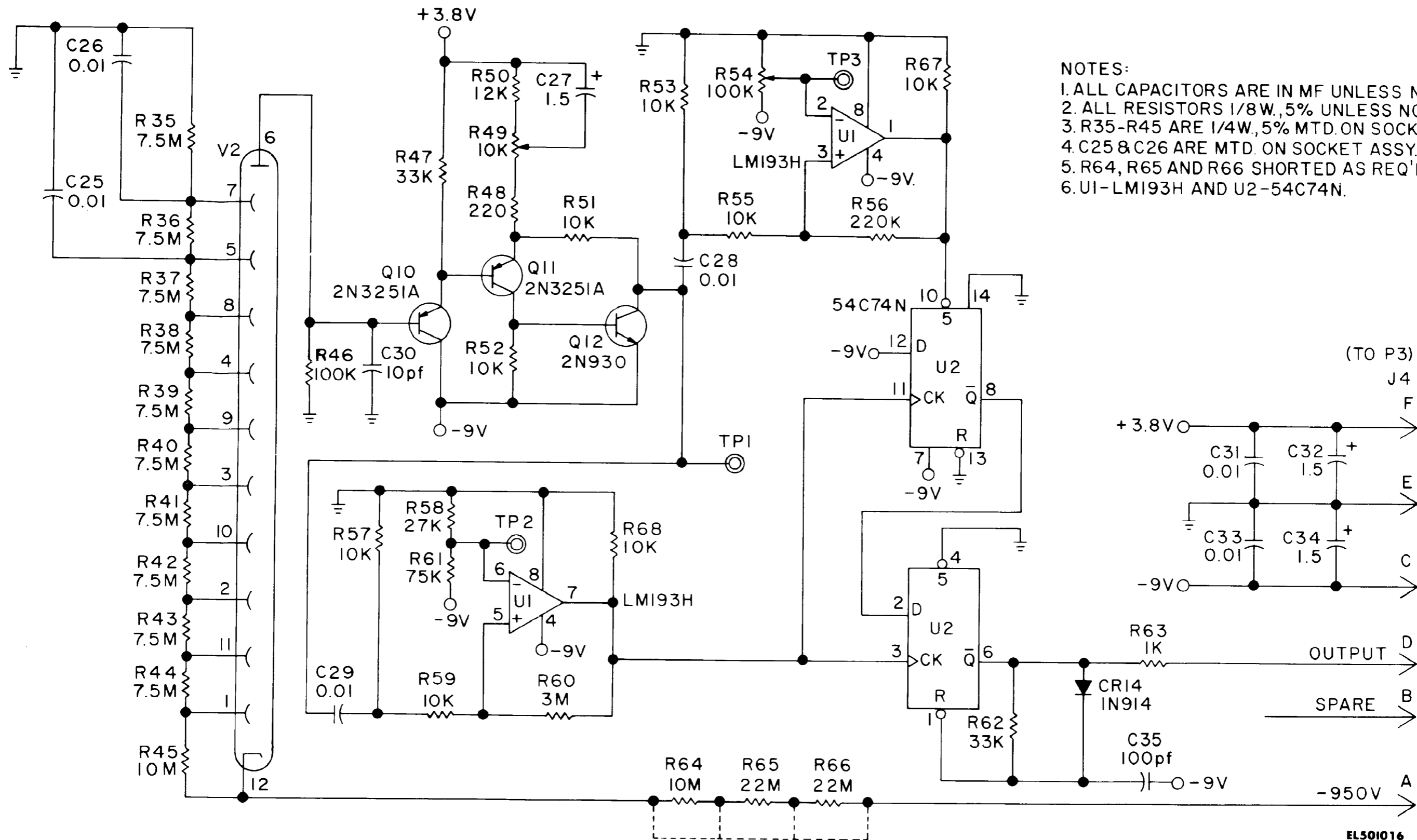

Figure 3-8. X-Ray Probe, DT-590A/PDR-56, PCB Parts Locations

APPENDIX A REFERENCES

DA Pam 310-1	Consolidated Index of Army Publications and Blank Forms.
DA Pam 738-750	The Army Maintenance Management System (TAMMS)
FM 21-11	First Aid for Soldiers.
TB 43-180	Calibration Requirements for the Maintenance of Army Material.
TM 11-5965-247-12P	Operator and Organizational Maintenance Repair Parts and Special Tools List and Maintenance Allocation Chart, Headset-Electrical H-43B/U.
TM 11-5965-247-35P	Field and Depot Maintenance Repair Parts and Special Tools List, Headset-Electrical H-43B/U.
TM 11-6665-245-12	Operator and Organizational Maintenance Manual, Radiac Set AN/PDR-56F (NSN 6665-00-211-6895).



- NOTES:
1. ALL CAPACITORS ARE IN MF UNLESS NOTED.
 2. ALL RESISTORS 1/8W., 5% UNLESS NOTED.
 3. R35-R45 ARE 1/4W., 5% MTD. ON SOCKET ASSY.
 4. C25 & C26 ARE MTD. ON SOCKET ASSY.
 5. R64, R65 AND R66 SHORTED AS REQ'D.
 6. U1-LM193H AND U2-54C74N.

EL501016

Figure FO-2. Overall Schematic, X-Ray Probe, DT-590A/PDR-56F

By Order of the Secretary of the *Army*:

Official:

ROBERT M. JOYCE
Major General, United States Army
The Adjutant General

E.C. MEYER
General, United States Army
Chief of Staff

DISTRIBUTION:

To be distributed in accordance with Special Mailing List.



THEN JOT DOWN THE DOPE ABOUT IT ON THIS FORM. CAREFULLY TEAR IT OUT. FOLD IT AND DROP IT IN THE MAIL.

SOMETHING WRONG WITH THIS PUBLICATION?

FROM (PRINT YOUR UNIT'S COMPLETE ADDRESS)
 Commander
 Stateside Army Depot
 ATTN: AMSTA-US
 Stateside, N.J. 07703

DATE SENT
 10 July 1975

PUBLICATION NUMBER: TM 11-5840-340-12
 PUBLICATION DATE: 23 Jan 74
 PUBLICATION TITLE: Radar Set AN/PRC-76

BE EXACT PIN-POINT WHERE IT IS				IN THIS SPACE TELL WHAT IS WRONG AND WHAT SHOULD BE DONE ABOUT IT:
PAGE NO	PARA GRAPH	FIGURE NO	TABLE NO	
2-25	2-28			<p>Recommend that the installation antenna alignment procedure be changed throughout to specify a 2° IFF antenna lag rather than 1°.</p> <p>REASON: Experience has shown that with only a 1° lag, the antenna servo system is too sensitive to wind gusting in excess of 25 knots, and has a tendency to rapidly accelerate and decelerate as it hunts, causing strain to the drive train. Hunting is minimized by adjusting the lag to 2° without degradation of operation.</p>
3-10	3-3		3-1	<p>Item 5, Function column. Change "2 db" to "3db."</p> <p>REASON: The adjustment procedure the the TRANS POWER FAULT indicator calls for a 3 db (500 watts) adjustment to light the TRANS POWER FAULT indicator.</p>
5-6	5-8			<p>Add new step f.1 to read, "Replace cover plate removed step e.1, above."</p> <p>REASON: To replace the cover plate.</p>
		F03		<p>Zone C 3. On J1-2, change "+24 VDC to "+5 VDC."</p> <p>REASON: This is the output line of the 5 VDC power supply. +24 VDC is the input voltage.</p>

7148 LONG PERFORATED IN

PRINTED NAME GRADE OR TITLE AND TELEPHONE NUMBER
 SSG I. M. DeSpirito 999-1776

SIGN HERE

RECOMMENDED CHANGES TO EQUIPMENT TECHNICAL PUBLICATIONS



THEN...JOT DOWN THE DOPE ABOUT IT ON THIS FORM. CAREFULLY TEAR IT OUT, FOLD IT AND DROP IT IN THE MAIL.

SOMETHING WRONG WITH THIS PUBLICATION?

FROM: (PRINT YOUR UNIT'S COMPLETE ADDRESS)

DATE SENT

PUBLICATION NUMBER

TM 11-6665-245-34

PUBLICATION DATE

14 Jan 83

PUBLICATION TITLE

Radiac Set AN/PDR-56F

BE EXACT PIN-POINT WHERE IT IS

PAGE NO.

PARA-GRAPH

FIGURE NO.

TABLE NO.

IN THIS SPACE TELL WHAT IS WRONG AND WHAT SHOULD BE DONE ABOUT IT:

PERFORATED LINE

TEAR

PRINTED NAME GRADE OR TITLE AND TELEPHONE NUMBER

SIGN HERE

DA FORM 2028-2 JUL 79

PREVIOUS EDITIONS ARE OBSOLETE

P.S.--IF YOUR OUTFIT WANTS TO KNOW ABOUT YOUR RECOMMENDATION MAKE A CARBON COPY OF THIS AND GIVE IT TO YOUR HEADQUARTERS.

FILL IN YOUR
UNIT'S ADDRESS

FOLD BACK

DEPARTMENT OF THE ARMY

OFFICIAL BUSINESS
PENALTY FOR PRIVATE USE \$300

POSTAGE AND FEES PAID
DEPARTMENT OF THE ARMY
DOD 314



TEAR ALONG PERFORATED LINE

Commander
US Army Communications-Electronics Command
and Fort Monmouth
ATTN: DRSEL-ME-MP
Fort Monmouth, New Jersey 07703

THE METRIC SYSTEM AND EQUIVALENTS

WEIGHT MEASURE

1 Centimeter = 10 Millimeters = 0.01 Meters = 0.3937 Inches
 1 Meter = 100 Centimeters = 1000 Millimeters = 39.37 Inches
 1 Kilometer = 1000 Meters = 0.621 Miles

WEIGHTS

1 Gram = 0.001 Kilograms = 1000 Milligrams = 0.035 Ounces
 1 Kilogram = 1000 Grams = 2.2 lb.
 1 Metric Ton = 1000 Kilograms = 1 Megagram = 1.1 Short Tons

LIQUID MEASURE

1 Milliliter = 0.001 Liters = 0.0338 Fluid Ounces
 1 Liter = 1000 Milliliters = 33.82 Fluid Ounces

SQUARE MEASURE

1 Sq. Centimeter = 100 Sq. Millimeters = 0.155 Sq. Inches
 1 Sq. Meter = 10,000 Sq. Centimeters = 10.76 Sq. Feet
 1 Sq. Kilometer = 1,000,000 Sq. Meters = 0.386 Sq. Miles

CUBIC MEASURE

1 Cu. Centimeter = 1000 Cu. Millimeters = 0.06 Cu. Inches
 1 Cu. Meter = 1,000,000 Cu. Centimeters = 35.31 Cu. Feet

TEMPERATURE

$5/9(^{\circ}\text{F} - 32) = ^{\circ}\text{C}$
 212° Fahrenheit is equivalent to 100° Celsius
 90° Fahrenheit is equivalent to 32.2° Celsius
 32° Fahrenheit is equivalent to 0° Celsius
 $9/5^{\circ}\text{C} + 32 = ^{\circ}\text{F}$

APPROXIMATE CONVERSION FACTORS

TO CHANGE	TO	MULTIPLY BY
Inches	Centimeters	2.540
Feet	Meters	0.305
Yards	Meters	0.914
Miles	Kilometers	1.609
Square Inches	Square Centimeters	6.451
Square Feet	Square Meters	0.093
Square Yards	Square Meters	0.836
Square Miles	Square Kilometers	2.590
Acres	Square Hectometers	0.405
Cubic Feet	Cubic Meters	0.028
Cubic Yards	Cubic Meters	0.765
Fluid Ounces	Milliliters	29.573
its	Liters	0.473
arts	Liters	0.946
allons	Liters	3.785
Ounces	Grams	28.349
Pounds	Kilograms	0.454
Short Tons	Metric Tons	0.907
Pound-Feet	Newton-Meters	1.356
Pounds per Square Inch	Kilopascals	6.895
Miles per Gallon	Kilometers per Liter	0.425
Miles per Hour	Kilometers per Hour	1.609

TO CHANGE	TO	MULTIPLY BY
Centimeters	Inches	0.394
Meters	Feet	3.280
Meters	Yards	1.094
Kilometers	Miles	0.621
Square Centimeters	Square Inches	0.155
Square Meters	Square Feet	10.764
Square Meters	Square Yards	1.196
Square Kilometers	Square Miles	0.386
Square Hectometers	Acres	2.471
Cubic Meters	Cubic Feet	35.315
Cubic Meters	Cubic Yards	1.308
Milliliters	Fluid Ounces	0.034
Liters	Pints	2.113
Liters	Quarts	1.057
ers	Gallons	0.264
ms	Ounces	0.035
ograms	Pounds	2.205
Metric Tons	Short Tons	1.102
Newton-Meters	Pounds-Feet	0.738
Kilopascals	Pounds per Square Inch	0.145
ometers per Liter	Miles per Gallon	2.354
ometers per Hour	Miles per Hour	0.621



PIN: 053646-001